

# Minicrusher

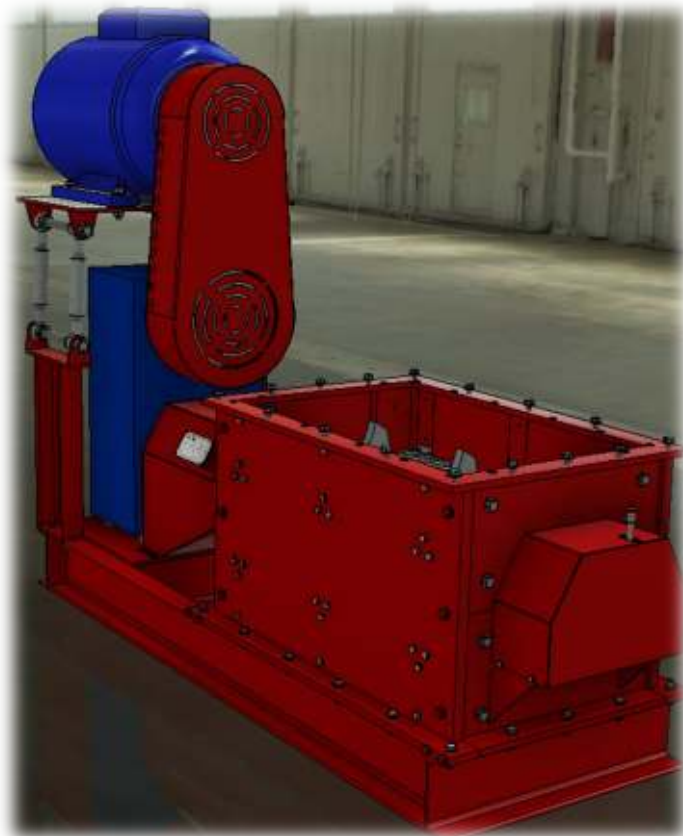

## Features

- Pre-break large pieces without preliminary cut-up.
- High-torque performance handles a broad range of feed stock
- Hardened machined teeth force material through the Minicrusher's rugged anvils with a low-speed shearing action instead of an impact or tearing action.
- The Minicrusher is designed to easily be able to remove parts for maintenance and replacing of parts.
- Shaft is completely customizable to swap out the 25mm blades for 12mm blades.
- Pre-break large pieces without preliminary cut-up.

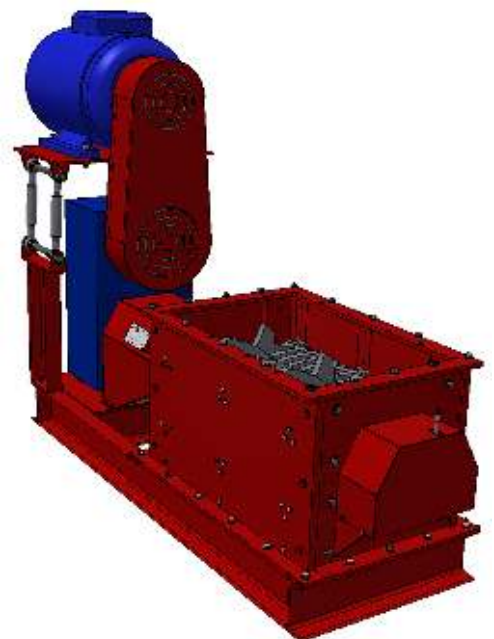

**MAVITEC**

# Minicrusher

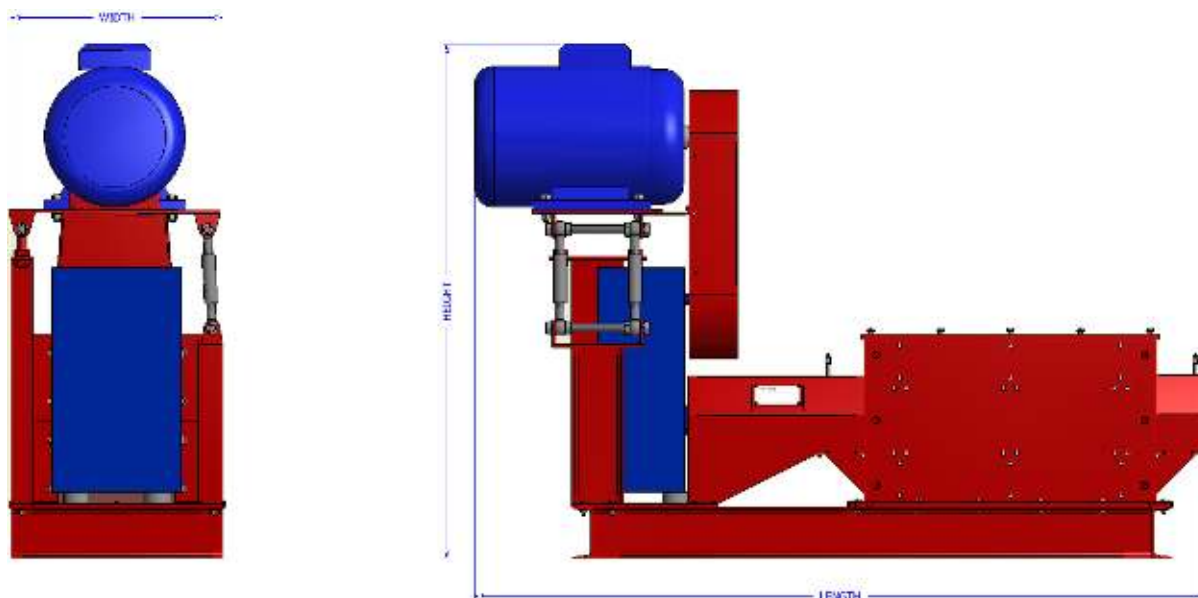

## Specifications

Crusher	Approx.					
Model	Capacity		Weight	Length (A)	Height (B)	Height (C)
	Ton/hr	kW	Kg	mm	mm	mm
Model 1	3-5	37	1500	2.251	1.700	650
Model 2	3-5	37	1700	2.112	1.700	720

Due to ongoing product improvements, data shown here is subject to change without notice.  
Contact Mavitec B.V. for latest specifications.

# MAVITEC

Galileistraat 32, 1704 SE Heerhugowaard, The Netherlands  
Tel.: +31 (0)72 574 59 88 - info@mavitec.com - www.mavitec.com

**Maximize the value of your by-products!**