

Metal Detector

Function

To detect and separate the ferro and non-ferro pieces from the raw or cooked material stream before entering the production process. This way the equipment is protected from substantial damage with less downtime and lower maintenance costs as a result. The clean end-product is collected in a collecting bin. The unit can be delivered as stand-alone unit or as integral part of a complete installation and is available as pipe, belt or free fall system. The unit is completed with steel support structure.

Models

Pipe Metal Detection System

- Pipe metal detection unit (tubular coil detector)
- Used for raw material stream
- Pneumatic actuated valves to determine the flow when ferro and non-ferro materials are detected
- Unit is completed with steel support structure



Belt Metal Detection System

- Horizontal metal detection unit (coil detector)
- Used for raw material stream
- Fat & oil resistant belt conveyor
- Stainless steel drip pan stops when ferro and non-ferro materials are detected
- Constant speed drive to obtain even layer of 50 mm for best detection results
- Unit is completed with steel support structure



Free Fall Metal Detection System

- Vertical metal detection unit (coil detector)
- Used for cooked material stream
- Heat resistant square tube
- Pneumatic diverter valve to determine the flow when ferro and non-ferro materials are detected
- Unit is completed with steel support structure



Metal Detector

Features

- Stainless steel execution
- Ring metal detector
- Variable speed drive
- Permanent magnets

Advantages

- Protects the process equipment from substantial damage
- Less downtime
- Lower maintenance costs

Pipe Metal Detection System

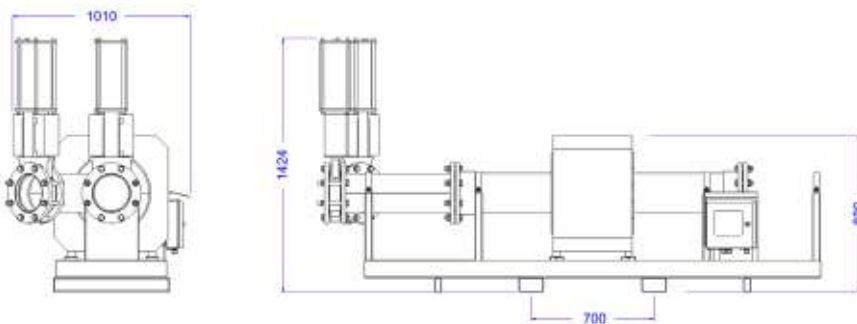

Free Fall Metal Detection System

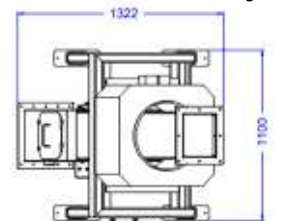

Belt Metal Detection System

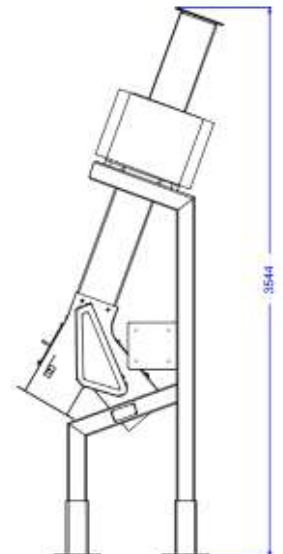
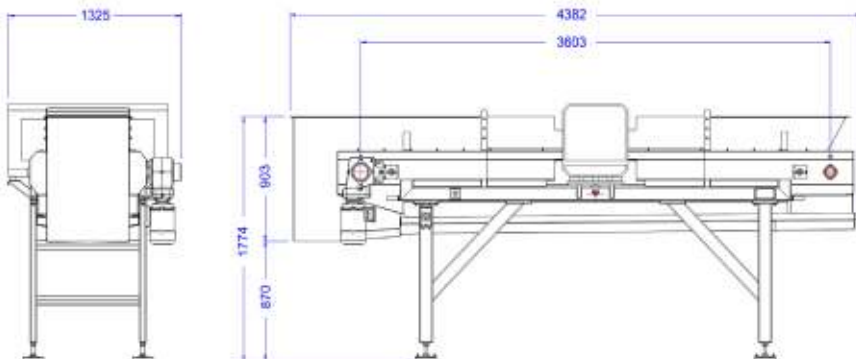

Due to ongoing product improvements, data shown here is subject to change without notice.
Contact Mavitec B.V. for latest specifications.

MAVITEC

Galileistraat 32, 1704 SE Heerhugowaard, The Netherlands
Tel.: +31 (0)72 574 59 88 - info@mavitec.com - www.mavitec.com

Maximize the value of your by-products!