

PCRS

Pressurized Condensate Return System

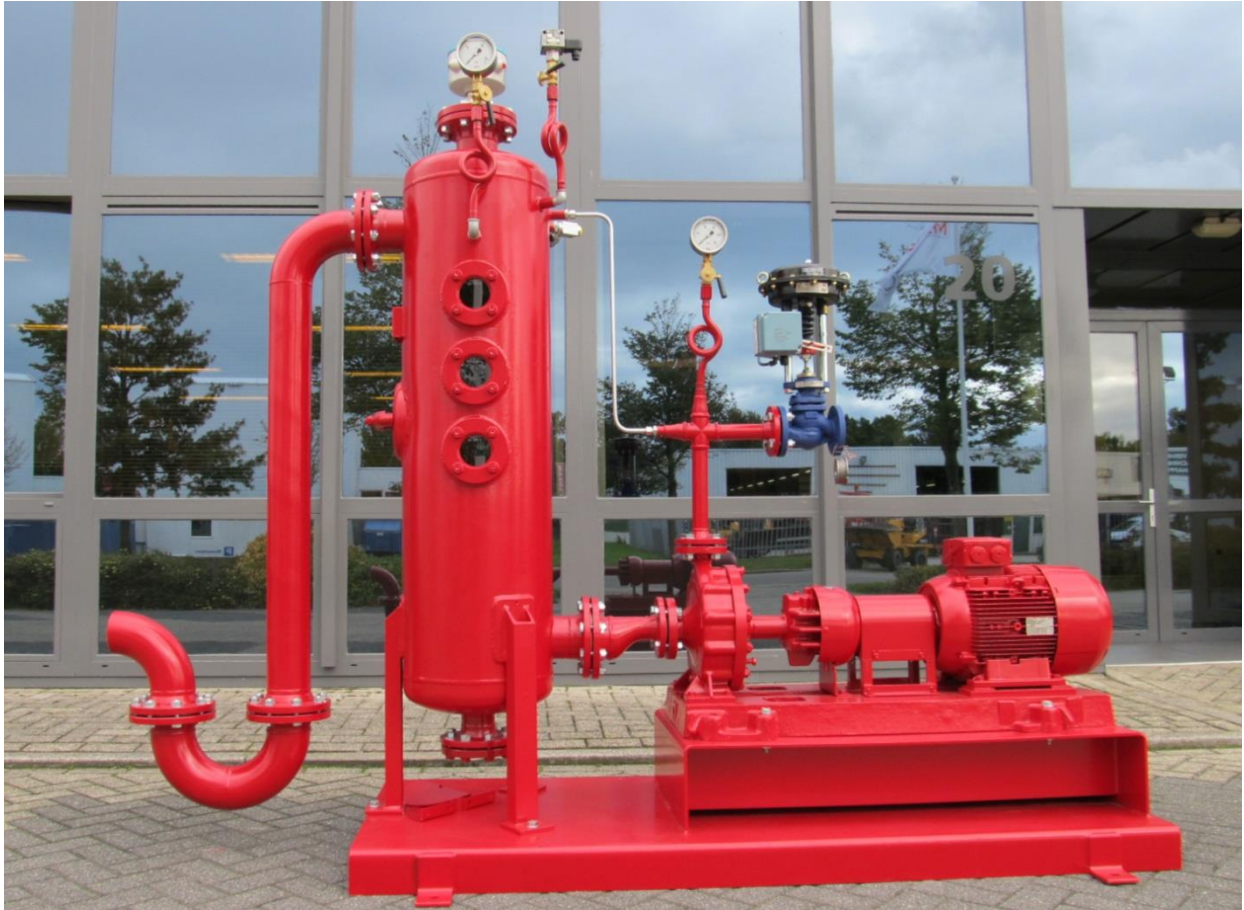

Features

- Skid mounted condensate collection and pumping system returns steam condensate directly to the boiler without flash losses.
- Reduces energy consumption over 15% @10bar(g) operation pressure.
- Reduces water consumption of the steam system.
- Reduces chemical consumption.
- Improves heat transfer performance.
- Various capacities and pump head pressures available.
- Optional: stand alone panel equipped with PID control system.



MAVITEC

PCRS

Pressurized Condensate Return System

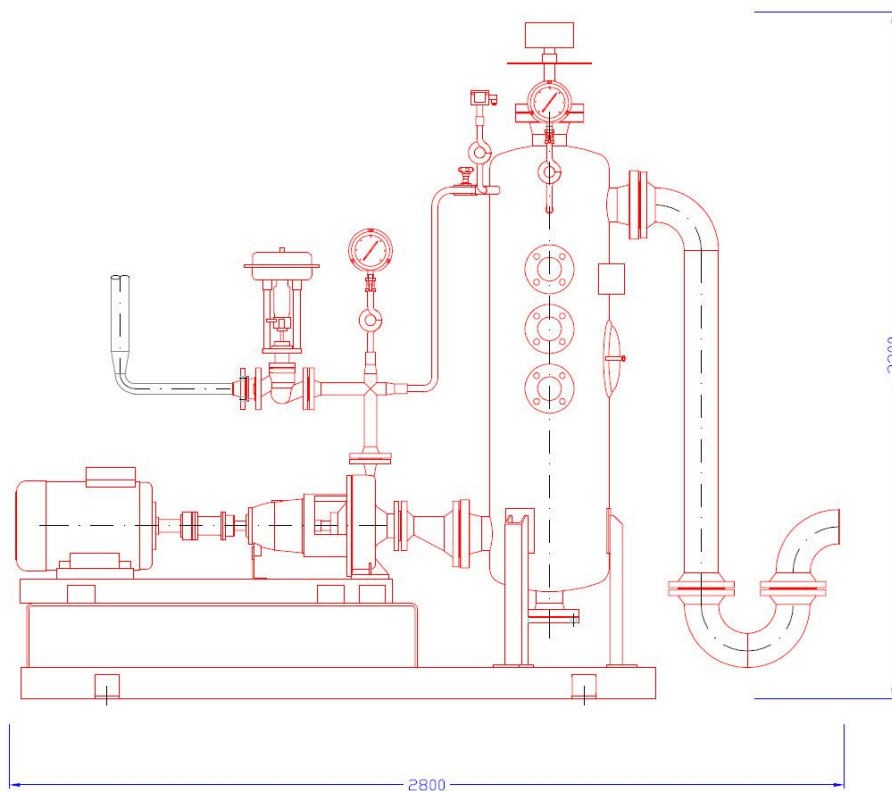
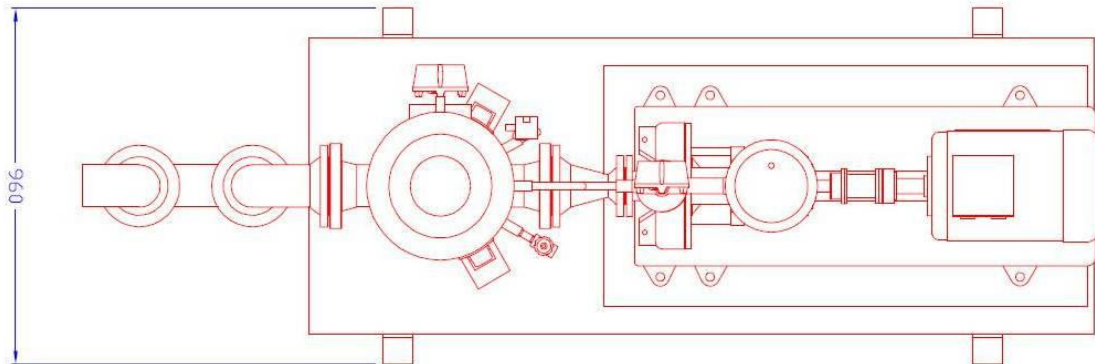

Due to ongoing product improvements, data shown here is subject to change without notice.
Contact Mavitec B.V. for latest specifications.

MAVITEC

Galileistraat 20, 1704 SE Heerhugowaard, The Netherlands
Tel.: +31-72-574 59 88 - Fax: +31-72-574 55 48
E-mail: info@mavitec.com - www.mavitec.com

DUPPS

Germantown, Ohio U.S.A.
Tel: +1-937-855 6555 • Fax: +1-937-855 6554
E-mail: info@dupps.com • www.dupps.com