

Metal Detector



Function: To detect and separate any metal pieces from your raw product before entering the production process

Features: Stainless steel execution with a ring metal detector and fat and oil resistant belt conveyor. The unit contains a stainless steel trough and drip pan with non-ferro removable side plates. The unit has a variable speed drive to obtain an even layer of 50 mm thickness of raw material to get the best detection results.

Unit can be delivered as stand- alone unit or as integral part of a complete installation. As alternative a vertical metal detector can be delivered in which any metal material is separated by a pneumatic valve. This unit is built on a stand-alone frame.

MAVITEC

Metal Detector

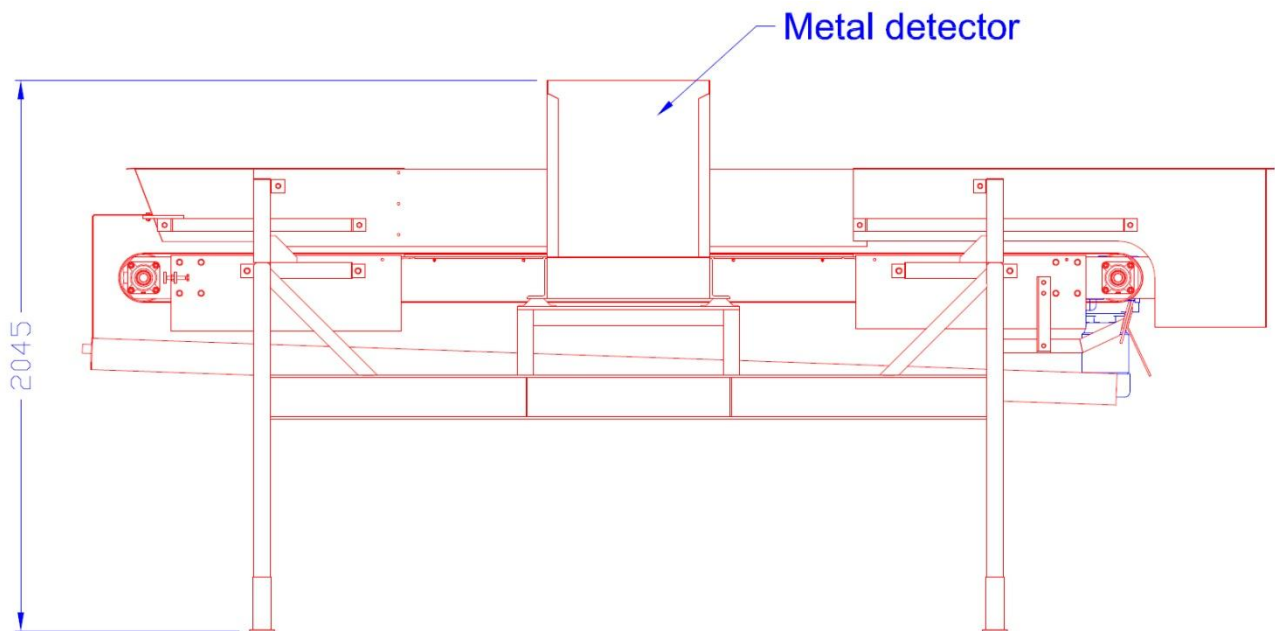
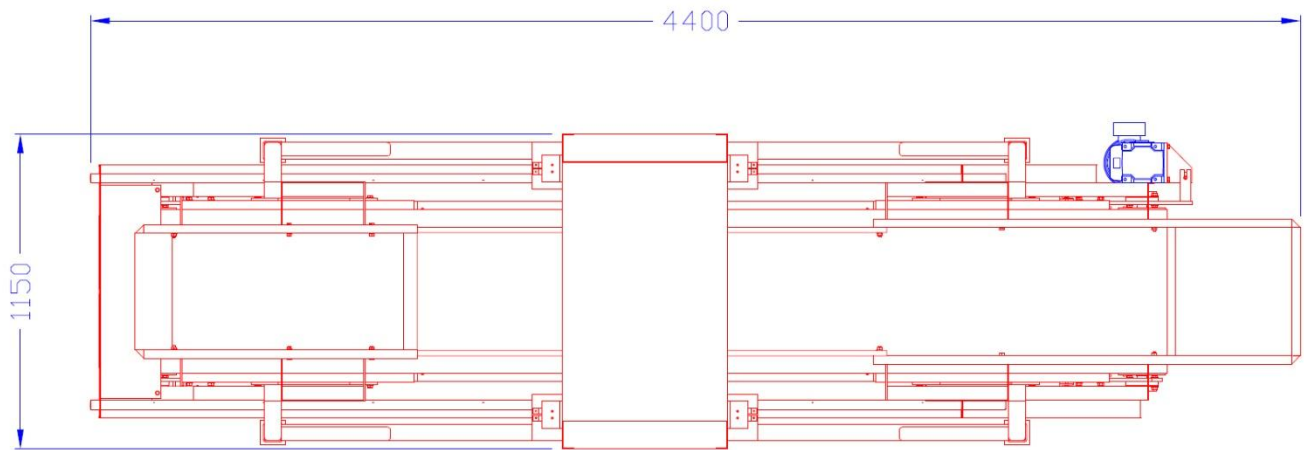

Due to ongoing product improvements, data shown here is subject to change without notice.
Contact Mavitec B.V. for latest specifications.

MAVITEC

Galileistraat 20, 1704 SE Heerhugowaard, The Netherlands
Tel.: +31-72-574 59 88 - Fax: +31-72-574 55 48
E-mail: info@mavitec.com - www.mavitecgreenenergy.com